

PANTHER T7R



PAYLOAD
15,432 lb • 7,000 kg



SPEED
8.1 mph • 13 km/h



CAPACITY
4.8 yd³ • 3.7 m³



ENGINE

Make/Model/Type	Caterpillar C4.4 Diesel engine	
Emission Level	EPA Tier 4 Final / EU Stage V	
Max Power Output	201 HP @ 2200 rpm	150 kW @ 2200 rpm

TRANSMISSION

Hydrostatic variable displacement pumps and motors

UNDERCARRIAGE

Track Type	Metal-embedded rubber track (MERT)	
Track Width	27.6 in	700 mm
Ground Clearance	15.2 in	387 mm
Ground Pressure		
without load	3 psi	20.68 kPa
with load	5 psi	34.47 kPa

BRAKE

Service Brake Wet Multiple Disk Brakes

PERFORMANCE

Payload	15,432 lb	7,000 kg
Travel Speed	8.1 mph	13 km/h
Dump Body Capacity		
Struck	4.33 yd ³	3.3 m ³
Heaped	4.8 yd ³	3.7 m ³
Operating Weight	23,567 lb	10,690 kg
Maximum Gradeability		
Uphill/Downhill	27%	15°
Side hill	27%	15°

FLUID CAPACITIES

Diesel Fuel	53 gal (US)	200 l
DEF / AdBlue [†]	5 gal (US)	19 l

ELECTRICAL SYSTEM

Voltage	12 V
Alternator Capacity	150 A
Battery Capacity	1150 CCA (two)

Pinoth[®]

EQUIPMENT

STANDARD EQUIPMENT

Operator environment

Spacious wide cab – 1 person
Tilt and telescopic steering wheel
Foot throttle pedal
Operator seat with suspension and adjustments
Air conditioning
Adjustable temperature, fan control and fresh air intake
Three-point seat belt
Front and rear wipers with adjustable speeds
Windshield washer
Two exterior mirrors (right-side remotely adjustable)
Main display 4.3 in (111 mm)

Safety

Rear and side-view cameras
Inclinometer built-in display's with adjustable alarms
Parking brake condition on seat belt and armrest
Side window emergency exit
ROPS ISO 3471
Back-up alarm
Horn
First aid kit
Fire extinguisher

Electrical and Lighting

Batteries maintenance-free (two)
Working lights, LED (two front, one rear)
Battery disconnect switch

Other

Pressurized hydrostatic oil tank
Lockable compartments for fluids and batteries
D-ring for transportation (two)
Lockable door
Spare parts catalog
Operating and maintenance manuals

OPTIONAL EQUIPMENT

Bluetooth Radio, USB and AM/FM	FOPS ISO 3449	Front brushguard
Flashing LED beacon light	Engine block and hydraulic oil heaters	Emergency driving system
Trainer seat	Engine coolant heater	

DIMENSIONS

A 116.3 in 2,955 mm	L 58.9 in 1,495 mm
B 97.8 in 2,485 mm	M 65.3 in 1,659 mm
C 70.3 in 1,785 mm	N 75.8 in 1,925 mm
D 15.2 in 387 mm	O 176.5 in 4,482 mm
E 27.6 in 700 mm	P 91.2 in 2,316 mm
F 206.5 in 5,246 mm	Q 111.2 in 2,825 mm
G 177.1 in 4,498 mm	r1 117.7 in 2,990 mm
H 150.0 in 3,811 mm	r2 110.7 in 2,811 mm
I 47.1 in 1,204 mm	a1 23°
J 112.3 in 2,853 mm	a2 33°
K 40.0 in 1,004 mm	a3 60°

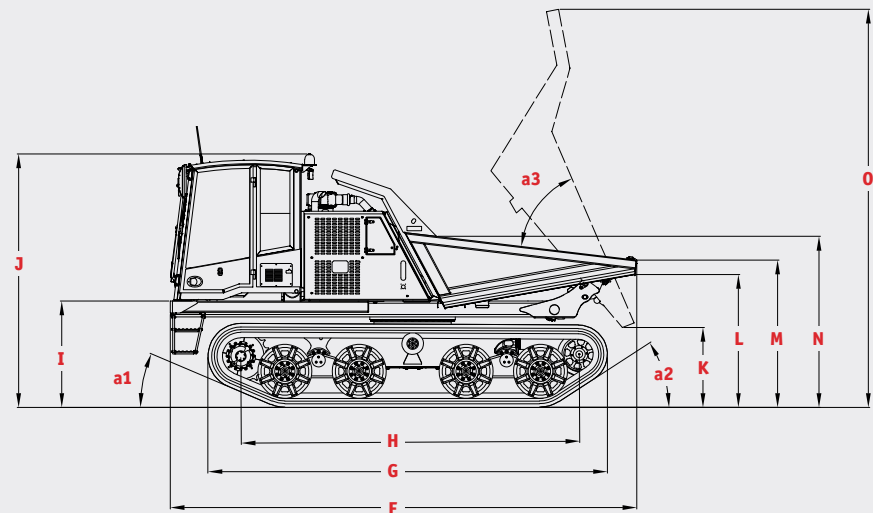
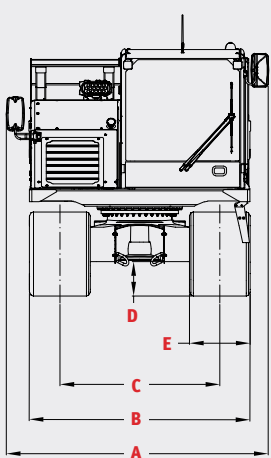
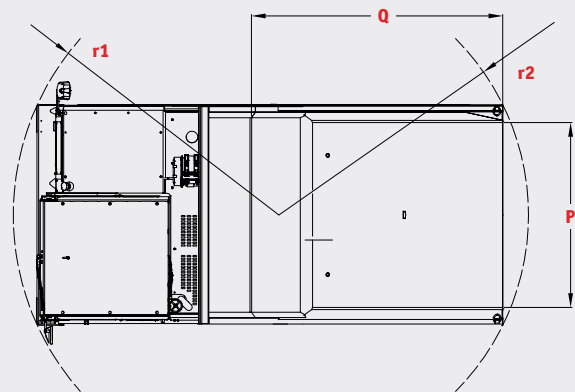

PRINOTH Ltd., 1001 J.-A. Bombardier Street, Granby QC J2J 1E9, CANADA
 Service: 450-776-3663 after.sales.service.na@prinoth.com
 Parts: 1-866-776-3636 parts.na@prinoth.com
 Sales: 450-776 3600 sales.na@prinoth.com

